

Innovation

Concentration

Intelligent

Profitable



FEATURES

- Components from world class suppliers
- Automotive class PCB technology
- Optimized thermal design
- Silicone Rubber Gaskets & Seals
- Integrated enclosure design
- Integrated air valve
- 1000 hours of neutral salt spray testing
- User friendly interface
- Intelligent monitoring system

ADVANTAGES

- Longer MTBF (Mean Time Between Failures)
- Higher quality guaranteed
- Lower heat generation
Faster heat dissipation
- High performance sealing
- High performance sealing possible
Less chance of moisture invasion
- Reduction of condensation
- Suitable for harsh environments
- Easy to operate
- Easy to manage and maintain

BENEFITS

- More electricity output
Less down time
- Higher quality guaranteed
- Reliable and stable under severe conditions
- Lower internal operation temperature
Longer component life
- Suitable for humid operation environments
- Operable in more applications: fishing ponds, agricultural area, greenhouses, coastal areas
- Easy installation and maintenance possible
- Data analysis
Less maintenance

CIRCUIT DIAGRAM

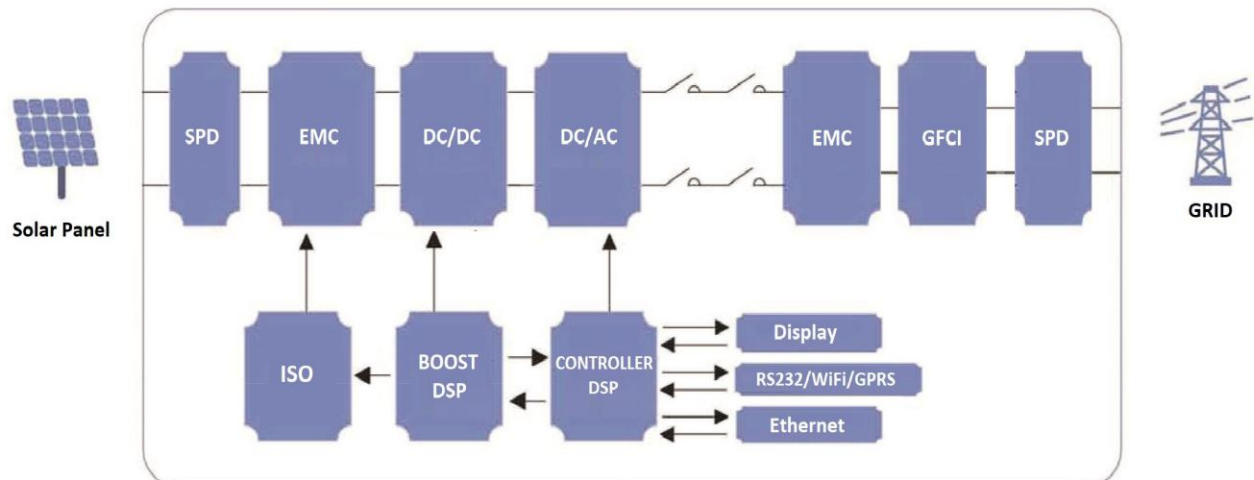

TECHNICAL DATA

Model	KSY-5KW	KSY-6KW	KSY-7KW	KSY-8KW	KSY-9KW	KSY-10KW	KSY-12KW
Input (DC)							
Nominal Input Power (KW)	5	6	7	8	9	10	12
Max. Peak DC Input Power (KW)	6	7	8	9	10	12	13.5
Max. DC I/P (V dc)	1000V DC						
Max. MPPT I/P Current(A)	20A						
MPPT Short Circuit Current(A)	26Amps.						
MPPT Tracking Voltage(Vdc)	200-1000V						
Min. Start/Shut down (V)	250VDC/ 150VDC(low) & 1000 VDC(High)						
Number of MPPT Tracker	1/2						
strings per MPPT Trackers	2						
Output (AC)							
Nominal Output Power (KW)	5	6	7	8	9	10	12
Max Peak Output Power (KW)	5.5	6.6	7.7	8.8	9.9	11	12.5
Nominal Grid Voltage (V)	320-470V User Defined						
Nominal Grid freq.(Hz)	47-55 HZ Auto Selection						
Max. output current AC(A)	8	9	10	11	13.5	15	18
AC Connection (With PE)	3P + N + E						
THD (%)	<2.3%						
Power factor(%)	>99.99%(User Defined from 0.85 to 0.99)						
Efficiency							
Max. conversion eff. (%)	98.5	98.6	98.6	98.7	98.7	98.8	98.7
Max. Euro Efficiency(%)	98	98.1	98.2	98.3	98.3	98.3	98.4
Max. MPPT Efficiency (%)	>99%						
Standards, Safety & Protections							
Protection & Safety	DC Reverse Polarity, DC High/Low/Over Current Protection, DC/AC Side SPD, Thermal Protection, GDT, Static ELCB/RCCB,User Define Grid Monitoring Setting & Anti Islanding						
SPD	Type-3 SPD With GDT						
MPPT Efficiency	EN 50530						
Inverter Efficiency	IEC 61685						
Protection Class	1(According to IEC 62103)						
Over Voltage Category	PVII / Mains II (According to IEC 62109-1)						
Safety Standard	IEC 62109-1&2						
EMC Standard	IEC61000-6-1/2/3/4						
Emnvironment Protection	IEC 60068-2-1/2/14/15						
Product Safty for relay	IEC 60255-27:2013						
Anti-Islanding	IEC-62116						
Ingress Protection	IP 65 (Accordance to IEC 60529)						
Physical Parameters							
Dimensions(WXHXD) mm	385 X 490 X 180						
Weight (Kg)	18		17			17	
General Data							
Operating Temperature	Minus 25 to Plus 60 Degree						
Design Life	Over 25 years						
Night Con. (W)/Noise Level	<0.2/<25dB						
Heat Dissipation	Natural Convection						
RH/Max. Altitude	0% to 98%. No Condensation/<2000 without power derating						
Display	LED with LCD Display						
DC /AC Connectors	MC-4/IP65 Plug						
Communication interface	RS 485/RS 232/Hotspot/WiFi/GPRS/ETHERNET LAN						
Standard Warranty	5 Years/10 Years (For Selected Model)						

Web Monitoring

The KSolare monitoring System is based on , cloud computing, and other new technologies for PV system, from the various device (RS-485,wifi, GPRS) the data is transmitted to remote service platform for data storage & analysis which is displayed in various visual & graphical formats on Web-App & big screen display also for bigger platform it can be customized as per customer request.

